



LabPro
Gelateria
-30°C

GELATEC

LAB
PRO

GELATEC



GELATEC OVERCOMES EVERY CHALLENGE!

We manufacture products beyond the limits of endurance and innovation, delivering maximum performance in extreme temperatures and demanding conditions.

Strength and reliability are at the core of every creation, while our commitment to environmental protection is non-negotiable.

We invest in top performance without compromising sustainability, building a world where durability meets responsibility.

DIMENSIONS

CABINET



INTERNAL CELL

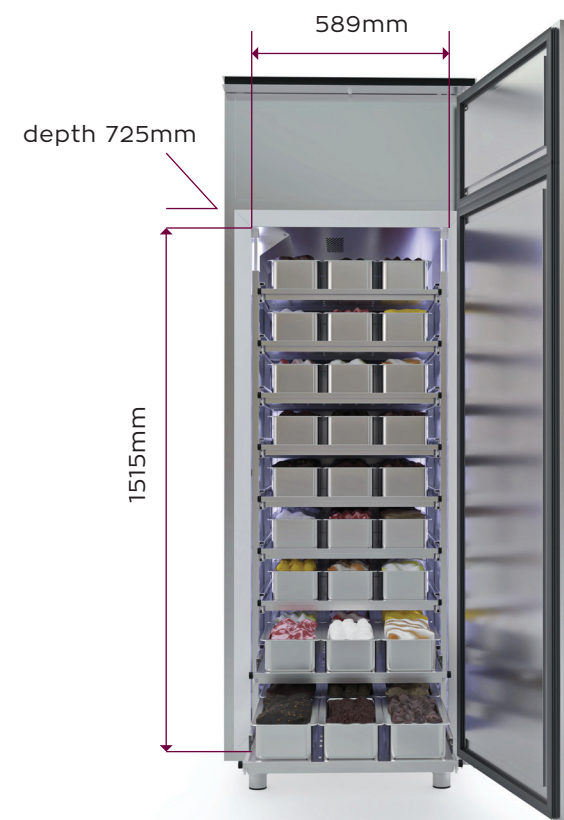

TRAY CAPACITY

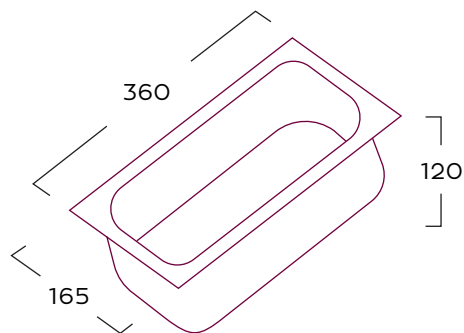

**STANDARD EDITION CAN HOLD
30 TRAYS IN 5 SHELVES**

MAX capacity can hold 54 trays in 9 shelves*

MAX CAPACITY

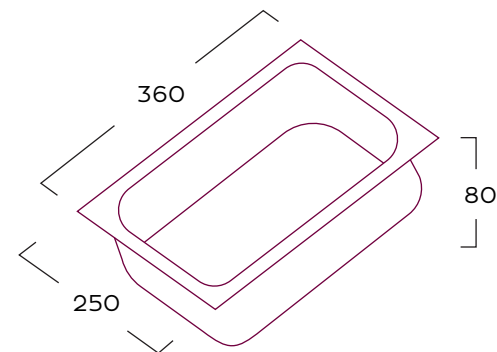
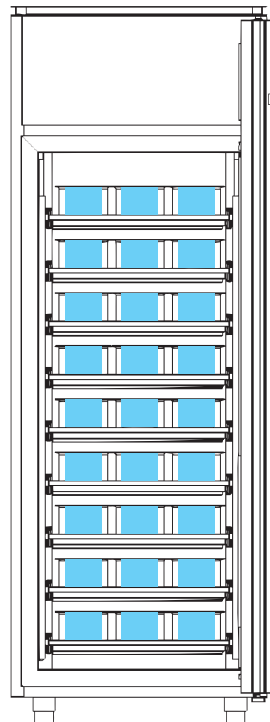

**STANDARD EDITION CAN HOLD
20 TRAYS IN 5 SHELVES**

MAX capacity can hold 36 trays in 9 shelves*

MAX CAPACITY

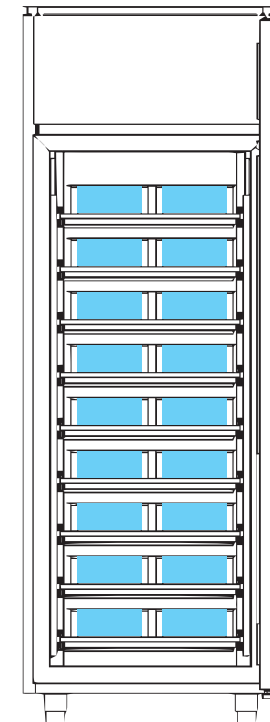

* note that the distance between the lower point of a shelf and the lower point of the upper shelf is 15cm!

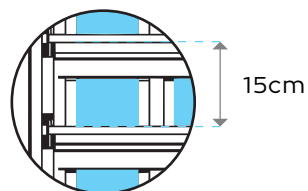

* note that the distance between the lower point of a shelf and the lower point of the upper shelf is 15cm!

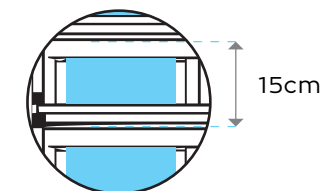

AVAILABLE COLORS

WITH BLACK HANDLE

STANDARD EDITION



Scotch brite



Mirror

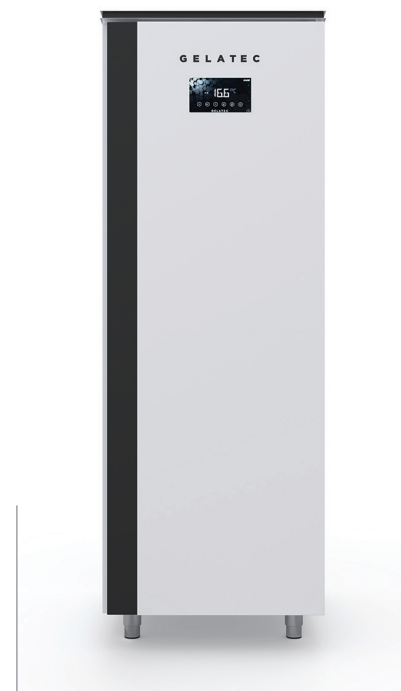

White

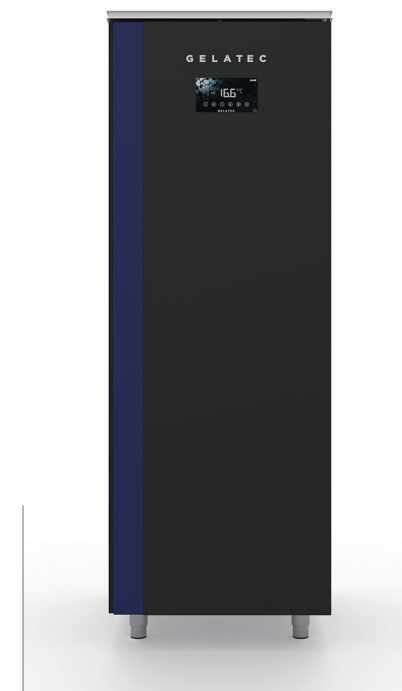

Black

AVAILABLE COLORS

WITH BLACK HANDLE

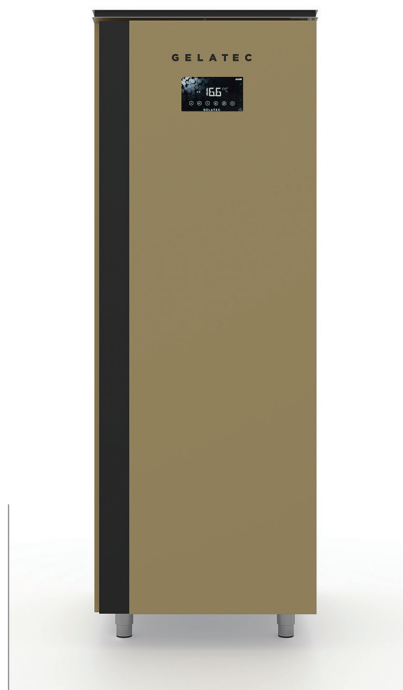

Gold

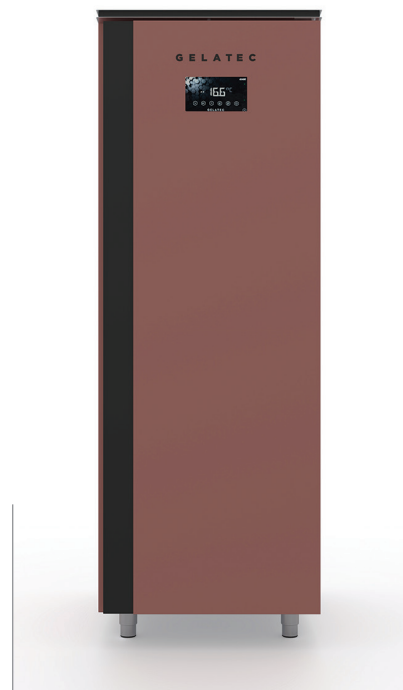

Cherry

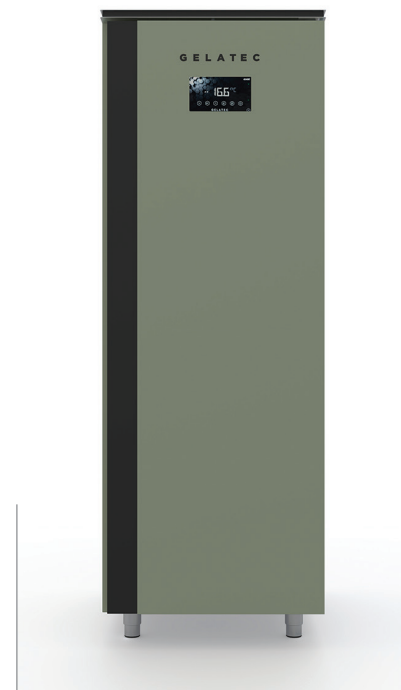

Pistachio

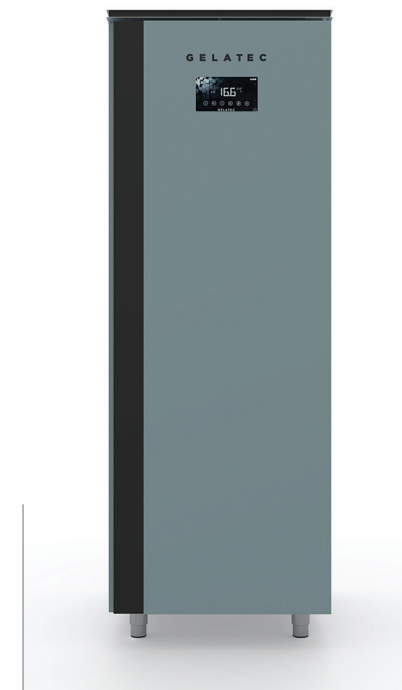

Cloud

AVAILABLE COLORS

WITH WHITE HANDLE

STANDARD EDITION

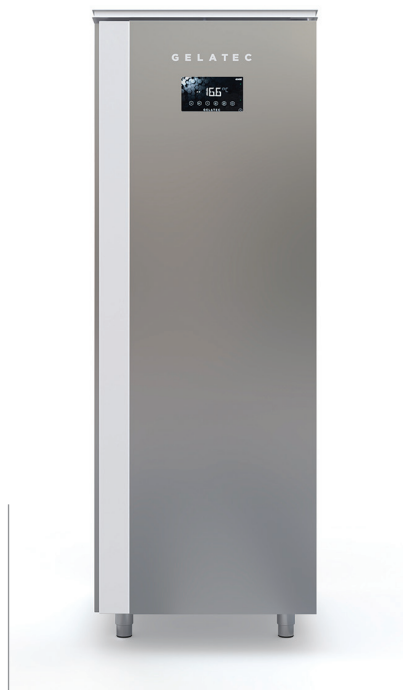

Scotch brite



Mirror

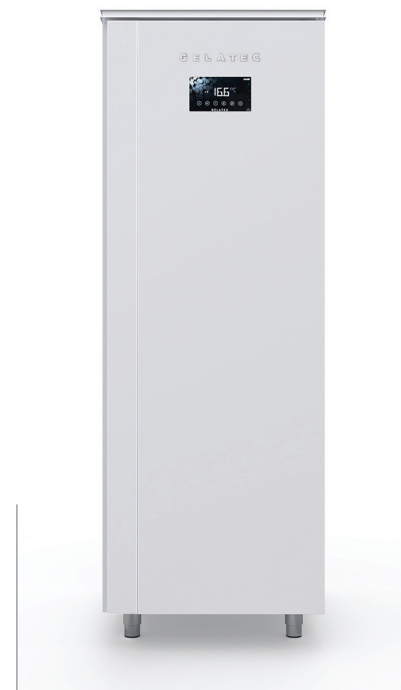

White

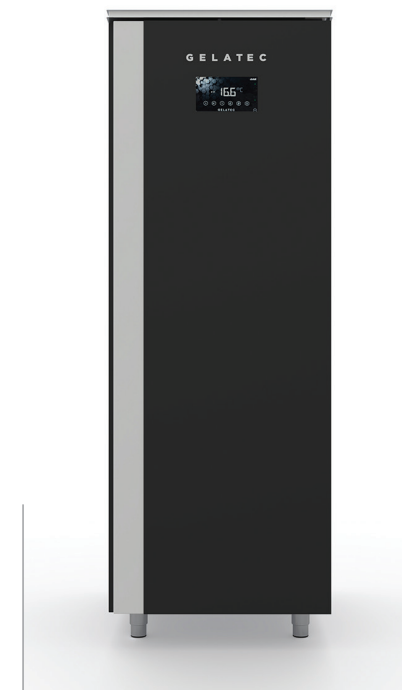

Black

AVAILABLE COLORS

WITH WHITE HANDLE

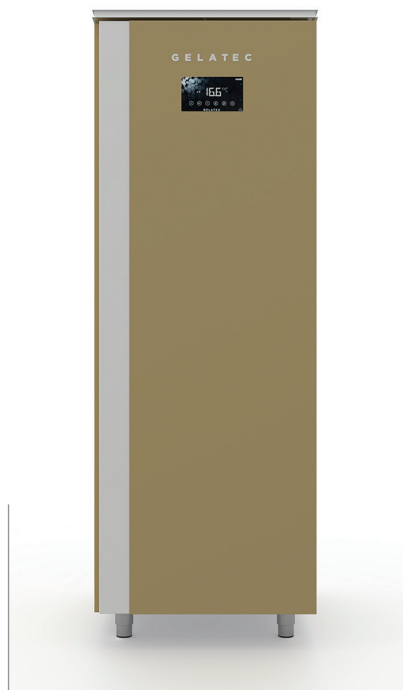

Gold

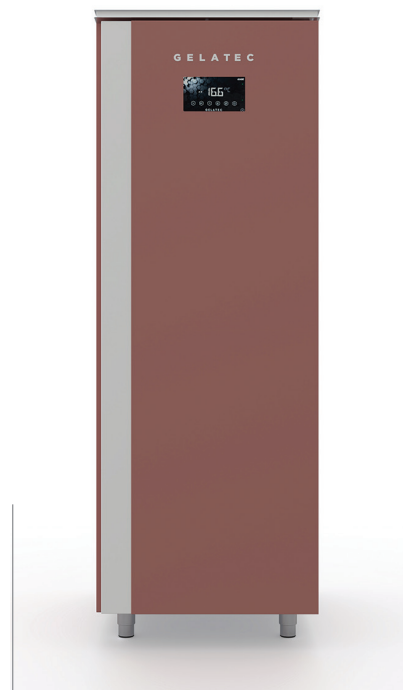

Cherry

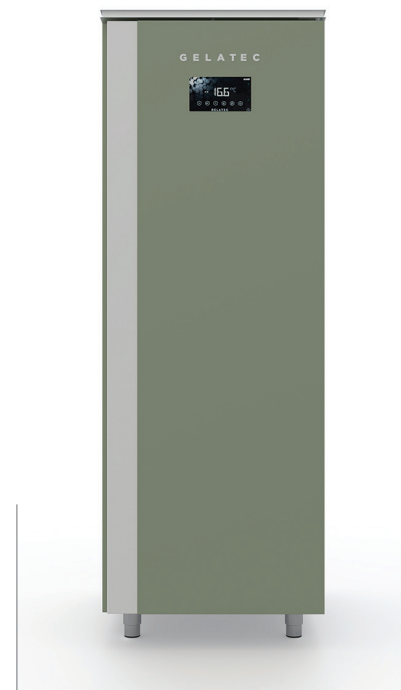

Pistachio

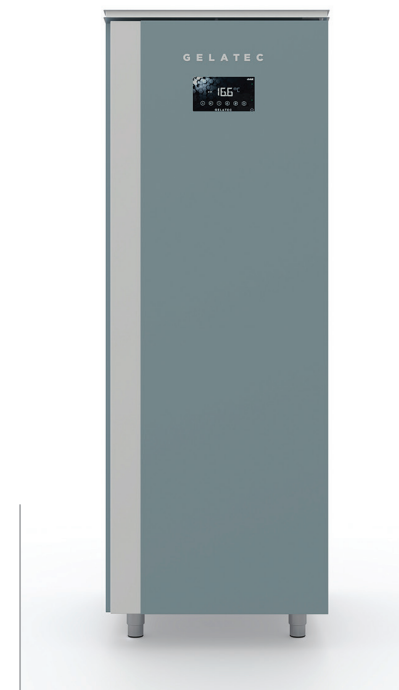

Cloud

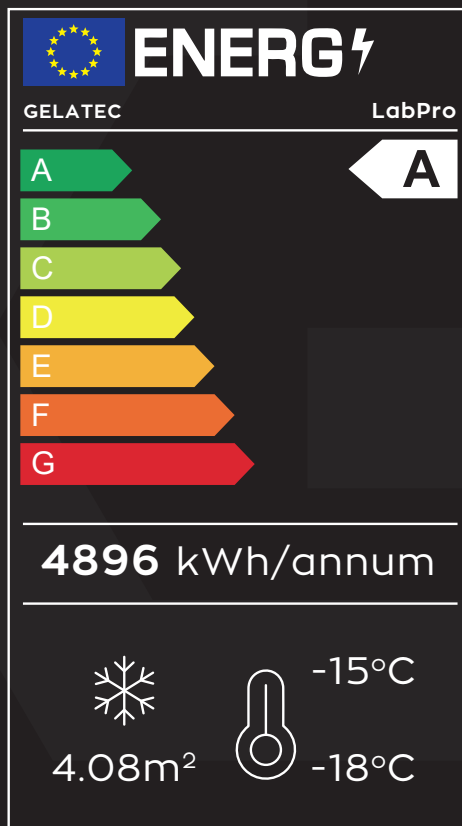

INNOVATION IN ENERGY EFFICIENCY

LabPro refrigerators integrate energy-saving technology that establishes new benchmarks within their class.

Using high-efficiency cooling systems, each unit is designed to minimize environmental impact without compromising performance.

REFRIGERATION

R290 eco-friendly refrigerant gas

LabPro refrigerators utilize R290, an eco-friendly refrigerant gas known for its minimal environmental impact. With a low Global Warming Potential (GWP) of 3, R290 reduces greenhouse gas emissions while offering excellent energy efficiency.

This natural refrigerant ensures powerful cooling performance, contributing to GELATEC'S commitment to sustainability and reduced energy consumption. R290 is non-toxic and highly effective, making it an ideal choice for modern, eco-conscious refrigeration solutions.



energy efficient



eco-friendly



*Global Warming
Potential*



NON Toxic

Designed to endure extreme conditions

Built to withstand the toughest environments, LabPro is equipped with advanced RIVACOLD refrigeration technology, offering exceptional performance and energy efficiency. High-efficiency compressors cut energy use by up to 10%, while a protected defrost and temperature probe prevent waste during door openings.

The robust refrigerant circuit, double-safety heating element, and ABS-injected base enhance insulation, strength, and drainage. Automatic condensing water evaporation and anti-corrosion oil treatment, ensure durability, while insulated plastic components provide reliable, long-term performance.

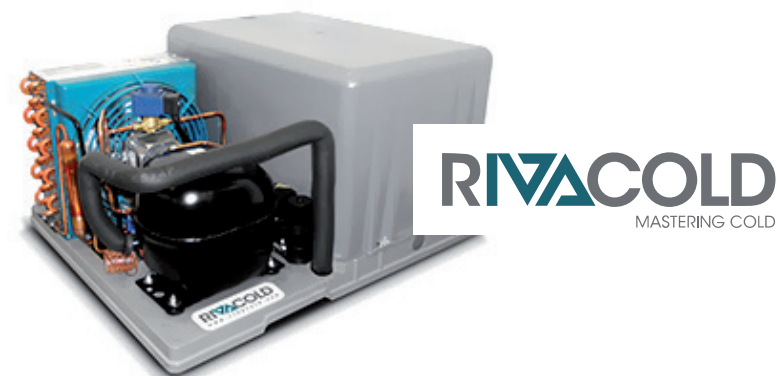

REFRIGERATION



Defrosting with SMART HOT GAS TECHNOLOGY

This innovation ensures swift and effective defrosting, minimizing the time the ice cream is exposed to temperatures that could compromise its quality.

It manages the gas circulation, dynamically adjusting the heat for defrosting, protecting the ice cream's quality while reducing energy consumption.

The result is a significant improvement in efficiency and a decrease in operating costs.

We guarantee that defrosting will become seamlessly integrated into the preservation process with superior preservation of your ice cream without any compromise in quality.

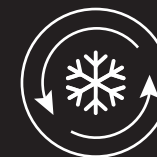
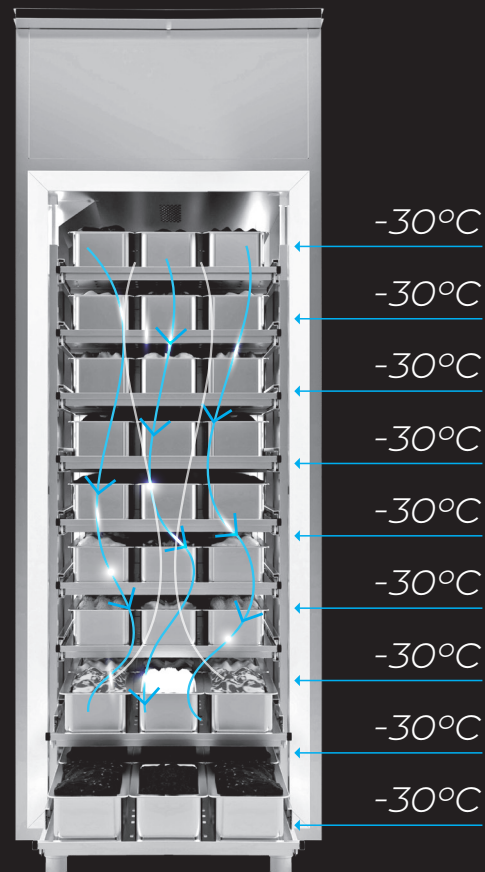

TEMPERATURE UNIFORMITY at every layer

Innovative engineering and advanced cooling technology guarantee that every level, from the highest to the lowest, remains at the ideal temperature for perfect ice cream preservation.

Ensuring temperature uniformity is crucial for maintaining the consistency and quality of the ice cream, avoiding temperature fluctuations that can result in undesirable recrystallization or melting.

CONSTRUCTION

Effortless and smooth door handling

The decompression valve is meticulously engineered to ease door opening and closing while preventing the vacuum effect that may occur due to pressure differentials between the chamber and the exterior of the refrigerator.

This decompression valve is essential for trouble-free operation in a high-use environment, as it guarantees that the door can be opened and closed easily every time, without effort.

This improves ergonomics and increases efficiency, while at the same time reducing the risk of damage from repeated use.

Wheel flexibility

As an alternative to standard legs, we offer the option to equip your refrigerator with durable wheels. This provides greater flexibility, allowing you to move the unit effortlessly for easy repositioning and cleaning, while maintaining the same level of stability.

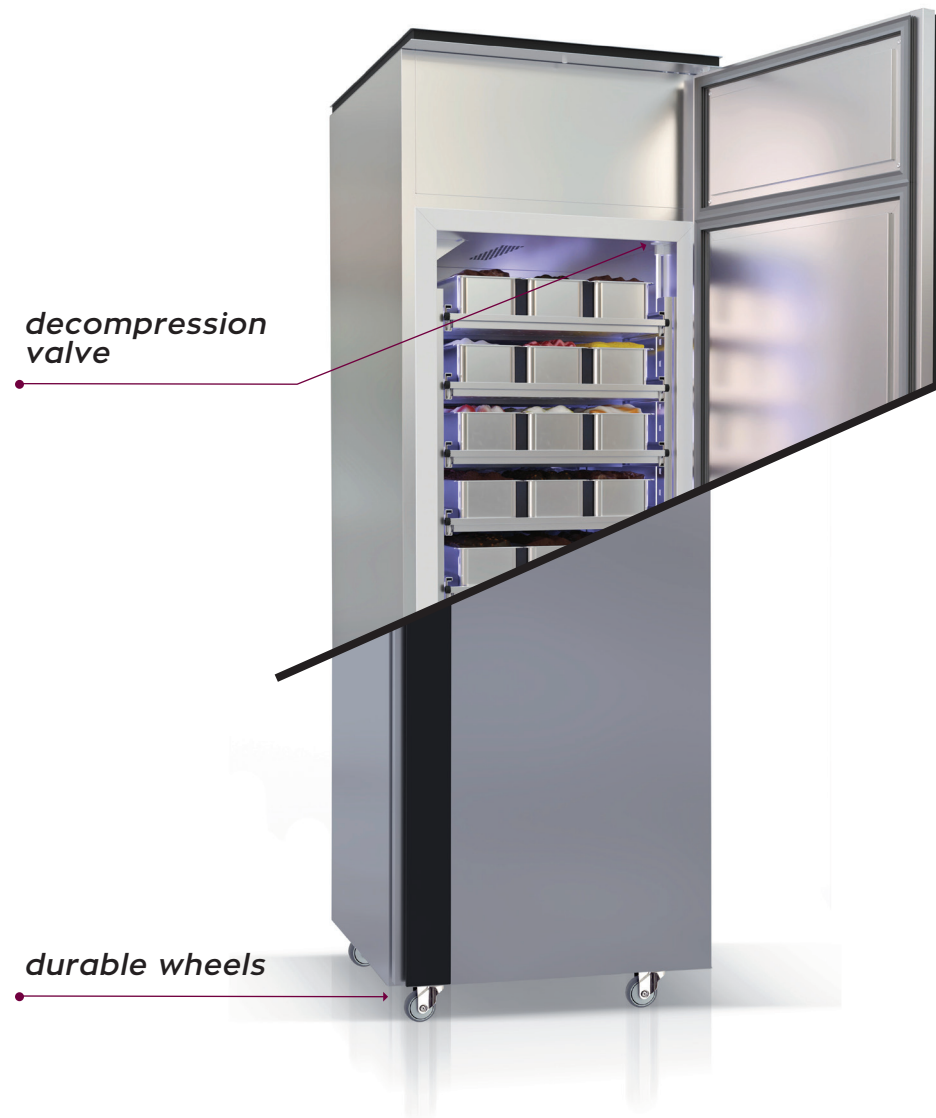

CONSTRUCTION

Heavy duty drawer slide system

GELATEC embraces cutting-edge technology in the design of LabPro chamber refrigerators by integrating FULTERER roller bearing drawer slides.

Engineered for unparalleled strength and reliability, these slides allow smooth and stable drawer movement even under heavy loads, ensuring effortless access, easy assembly and disassembly, and safe use.



Safety lock

The optional safety lock provides an added layer of security for your refrigerator.

Designed for peace of mind, it ensures controlled access and protection, offering an extra safeguard for your valuable products.



CONSTRUCTION

Superior durability with AISI 304 stainless steel

AISI 304 stainless steel is a popular austenitic grade due to its versatile properties, ensuring excellent corrosion resistance and protection against oxidation in harsh environments.

Additionally, this alloy is highly durable, capable of withstanding a range of environmental conditions and temperatures without degrading, ensuring long-term reliability and performance

Top insulation with ecological polyurethane

At the core of LabPro's efficiency and sustainability lies the groundbreaking 42kg/m^3 eco-friendly polyurethane insulation with its exceptional properties in maintaining temperature preservation and its unparalleled durability over time, while respecting the environment.

It ensures remarkable energy efficiency, minimum energy losses and also that the interior of the refrigerator remains at the optimal temperature to preserve the ice cream.

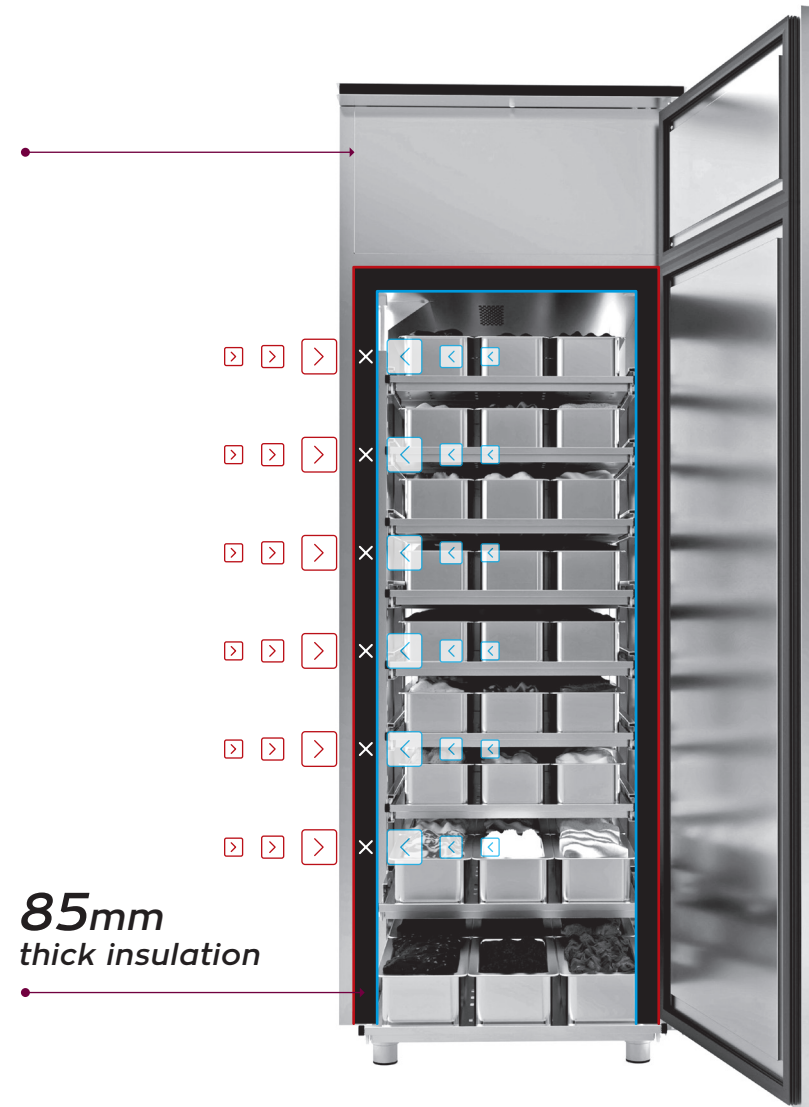

ELECTRONICS

High-brightness LED lighting

Enhance the visibility and organisation of your stored products with LabPro chamber refrigerators' advanced LED lighting. This system ensures clear and bright illumination within the storage unit, making it easier to manage inventory and access products.

In addition, it is energy-efficient, helping to reduce operational costs while maintaining optimal performance and supporting sustainability.

Innovative Wi-Fi control

LabPro refrigerators address the need for instant control and adaptability with built-in Wi-Fi control functionality. Adjust temperature settings, monitor energy consumption, receive notifications for equipment maintenance at any time, safely and securely with our advanced mobile app.

This feature not only guarantees enhanced performance and longevity for your equipment but also provides smarter and more cost-effective resource management.

99% CRI

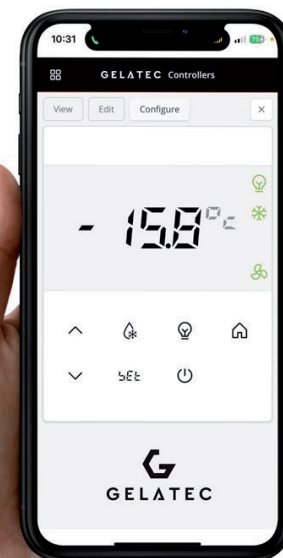

PERFORMANCE EXCEEDING ALL PREDICTIONS

LabPro refrigerators combine unparalleled performance with superior energy efficiency. Each unit is equipped with a peak cooling system that guarantees temperature uniformity across all compartments, assuring the quality and freshness of the ice cream.

Using state-of-the-art refrigeration technologies and powerful cooling efficiency systems, our chillers ensure uniform and consistent temperature maintenance, preserving your ice cream in perfect condition.

Strong cooling performance enables our refrigerators to respond quickly to changes in outdoor temperature and promptly restore to the optimal temperature after each opening, guaranteeing the utmost preservation and quality of the ice cream.

TECHNICAL SPECIFICATIONS

Electric supply	220 - 240V 50Hz		
Performance		R290	R452
Condensation type	AIR COOLED		AIR COOLED
Configuration		-10 -30	-10 -30
Power consumption	W	828	901
Current consumption	A	4.84	3.82
Main power cable	mm2	3G1.5	3G1.5
Refrigeration power (-20/+40°C Suction gas +20°C Subcooling 0 K)	W	617	588
Expansion	Capillary		Capillary
Air flow for ventilation	m3/h	554	600
Air flow for condenser	m3/h	394.2	378.6
Defrost Type		Hot Gas	Hot Gas
Noise	32dBA		
Gas	KG	0.15	0.45
Polyurethane foam (42kg/m3)	mm	85	85
Climate class		class 5 = 40°C	class 5 = 40°C



OUR PARTNERS

Over the years, we have built strong, enduring partnerships with trusted industry leaders. These relationships are grounded in mutual trust, shared values, and a commitment to excellence.

Our partners rely on us as much as we rely on them, ensuring the highest standards of quality and success in every collaboration.

The logo for ABB, consisting of the letters 'ABB' in a bold, red, sans-serif font.The logo for Danfoss, featuring the word 'Danfoss' in a red, cursive script font.The logo for Dixell, with the word 'Dixell' in a bold, black, sans-serif font and a small 'TM' trademark symbol.The logo for DORIN INNOVATION, featuring a circular emblem with a stylized 'AD' monogram on the left and the text 'OFFICINE MARIO DORIN SINCE 1918' above 'DORIN INNOVATION' on the right.The logo for Embraco Nidec, with 'embraco' in a teal, sans-serif font and 'Nidec' in a green, italicized, sans-serif font below it.The logo for ebmpapst, with 'ebmpapst' in a blue, sans-serif font.The logo for Fulterer, featuring the word 'Fulterer' in a white, italicized, sans-serif font centered within a solid red square.The logo for RIVACOLD, with 'RIVACOLD' in a blue, sans-serif font and 'MASTERING COLD' in a smaller, black, sans-serif font below it.The logo for Tecumseh, featuring a blue circular emblem with a stylized figure on the left and the word 'Tecumseh' in a black, cursive script font on the right.The logo for TEVE, featuring a circular emblem with 'Despina' at the top, 'TEVE' in the center, and 'Klidara' at the bottom, all within a blue circular border.



GELATEC

Thessaloniki | Industrial Area, Block 48B

P.BOX: 1005 PC. | 57022 Sindos, Greece

Tel / Fax: +30 2310 797707 | Email: info@gelatec.it

www.gelatec.gr